

The MCT-LL 4A Series  
Liquid Level Analog Output  
High Level Analog Output  
3.3 & 5.0 Vdc Supply Voltages

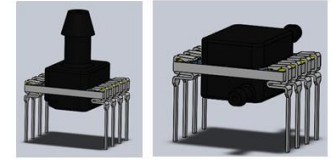

### DESCRIPTION

Advanced Sensors Multi Chip Technology Liquid Level (MCT-LL) Analog Output Voltage Series utilizes a unique two-piece pressure port design and advanced Dimethyl Silicone elastomer that ensures the highest level of isolation of the sensor and electronics from the liquid media. With AVSensors advanced mixed signal ASIC (Application Specific Integrated Circuit) and RTV bonded silicon MEMS gage sensor a high level analog output for measuring liquids in open and closed containers can easily be measured. The design's superior performance provides 1% Total Error across a wide temperature range of -0 to 85° C. With all the advanced features, the MCT-4LL A series is the ideal choice for measuring container height for many applications .

### APPLICATIONS

- Open Vessel Liquid Level Measurements
- Pressurized Vessel Level Measurements
- Mildly Corrosive Liquid Level Measurements
- 

### FEATURES

- Unique Two Piece Port Design
- Low Power Option
- 3.3 & 5.0Vdc Supply Voltages
- Advanced Silicone Elastomers for Superior Isolation
- Low Overall Errors, 1%TEB
- Custom Outputs and Ranges Available
- Ratiometric, Analog Voltage Output

### SPECIFICATIONS

	Symbol	Min	Typical	Max	Unit	Note
<b>Performance Specifications</b>						
Supply Voltage		2.7V	3.3	5.50	V	
Current Consumption				3	mA	
Current Consumption, -L Option			0.25		mA	
Pressure Accuracy		-0.25		0.25	mA	2
Total Error Band,	TEB	-1.00		1.00	%FSS	3
Output DAC Resolution				12	bits	
Output (Type 1) at Pmin			10		%Vdd	
Output (Type 1) at Pmax			90		%Vdd	
Output (Type 2) at Pmin			5		%Vdd	
Output (Type 2) at Pmax			95		%Vdd	
Conversion Time			1.0		mS	4
Power On to Valid Data				<10	mS	5
Weight				3	grams	
Compensated Temperature			-0 to 85		°C	6
Operating Temperature			-40 to 125		°C	6

SPECIFICATIONS	Symbol	Min	Typical	Max	Unit	Note
<b>Absolute Maximum Conditions</b>						<b>10</b>
Supply Voltage		-5.0		6	V	
Storage Temperature		-40		125	°C	6
Package Integrity, Common Mode				300	psi	7
Proof Pressure				3x		8
Burst Pressure				5x		9
Media Compatibility		CDA, Non Ionic, Non Corrosive Gases				
Wetted Materials		Ceramic, RTV, Epoxy, Silicon, Gold, Aluminum, LCP				

**Reference Conditions:** Vsupply: 3.30Vdc or 5.00, Ta=25 °C, Positive Pressure Port A

1. All specification at reference conditions unless otherwise noted.
2. Maximum deviation from a Best Fit Straight Line through Pmin and Pmax measured at 25 °C. Errors included Pressure Non Linearity, Pressure Hysteresis and Repeatability.
3. Maximum deviation from the Ideal Transfer Function expressed as a percentage of the %FSS over the compensated temperature range. Includes calibration errors (Offset & Span), temperature errors (Offset & Span), pressure non-linearity, pressure and thermal hysteresis.
4. The time for the output DAC to be updated with new data.
5. The time for the output DAC to have valid data after a power on reset.
6. Compensated, operating and storage temperatures for mBar/inH2O ranges are 0 °C to 60 °C, -10 °C to 85 °C, and -20 °C to 105 °C respectively
7. Maximum pressure the sensor package can withstand without rupture.
8. Maximum pressure without degrading sensor's performance specifications.
9. Maximum pressure the silicon diaphragm can withstand without rupture.
10. Exceeding Absolute Maximum Specification may damage the device. Extended exposure beyond the operating conditions may affect device reliability.
11. Enabled Diagnostic option will clip the output voltage at 5% and 95% of supply voltage. Output will remain within 2.5% of the supply rails when the diagnostic is triggered.
12. Switch Port option will change the Positive Pressure Port to B on dual pressure port configurations (VHD, HBD).
13. Potted Gel option will use a two piece port design having the same dimensions and made from the same material.

### PRESSURE TRANSFER FUNCTIONS

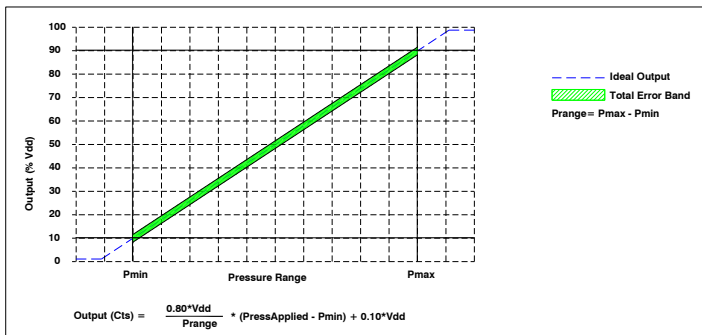

Type 1, 10-90%, Pressure Transfer Function

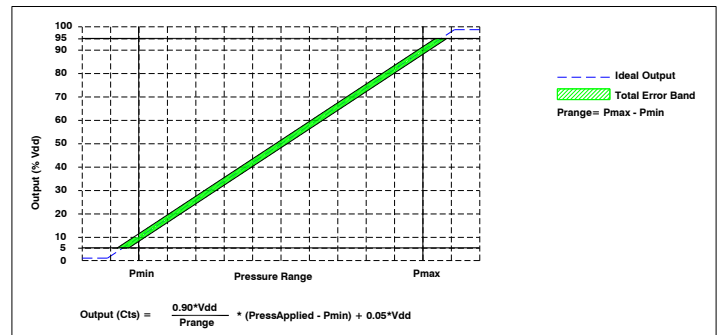

Type 2, 5-95%, Pressure Transfer Function

### MECHANICAL DIMENSIONS in [mm]

## DUAL IN LINE, THRU HOLE

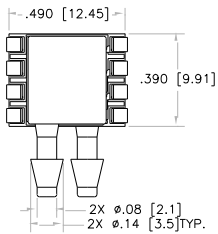

HORIZONTAL BARB, DUAL

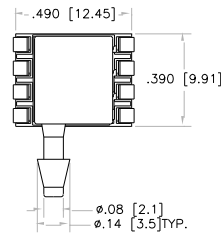

HORIZONTAL BARB, TOP

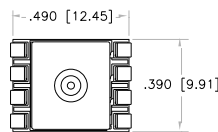
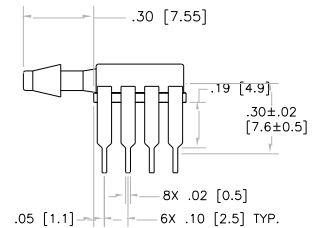
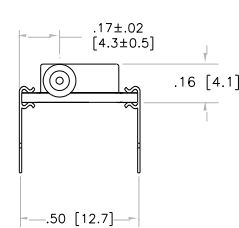
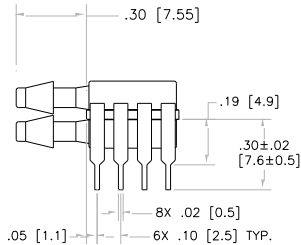
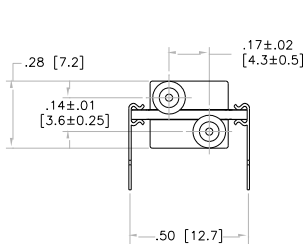

VERTICAL BARB, TOP

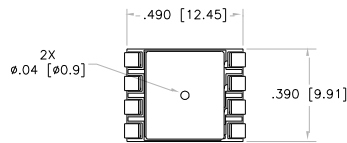

VERTICAL HOLE, DUAL

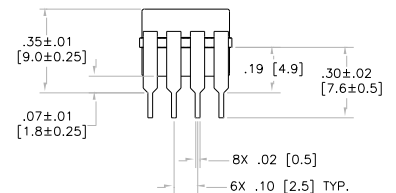
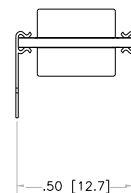
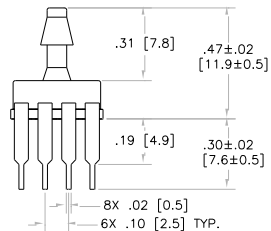
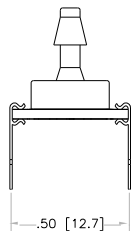

# DUAL IN LINE, J LEAD SMT

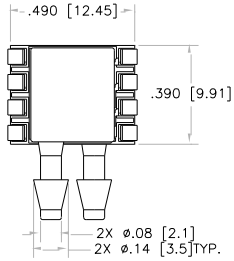

**HORIZONTAL BARB, DUAL**

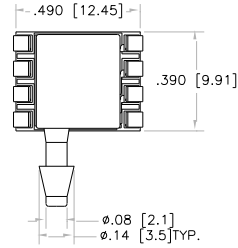

**HORIZONTAL BARB, TOP**

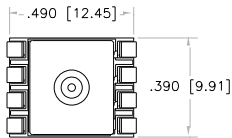
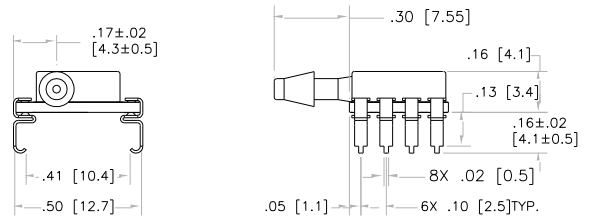
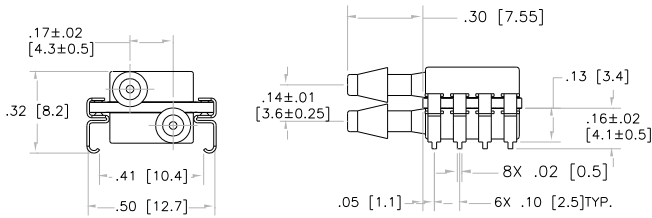

**VERTICAL BARB, TOP**

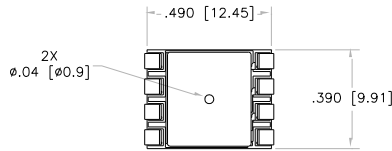

**VERTICAL HOLE, DUAL**

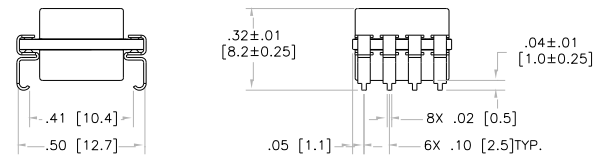
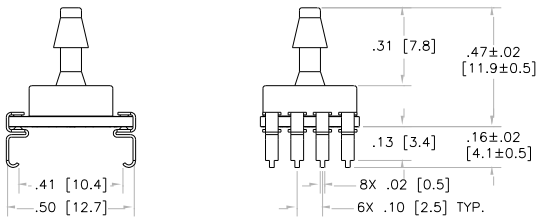

# SINGLE IN LINE, S & SL LEAD

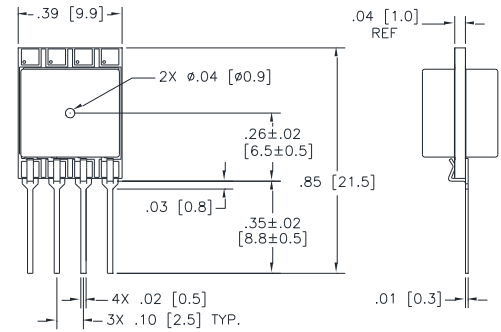
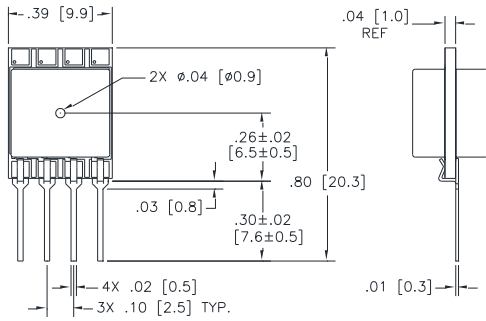
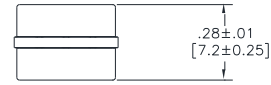
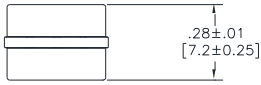

VERTICAL HOLE, DUAL  
S PIN STYLE

VERTICAL HOLE, DUAL  
SL PIN STYLE

### PORT DESIGNATION

HORIZONTAL BARB, DUAL

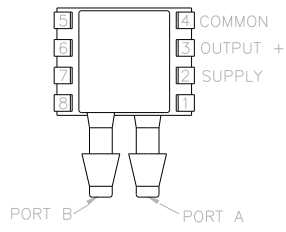

HORIZONTAL BARB, TOP

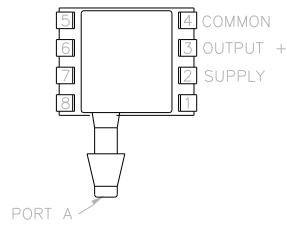

VERTICAL BARB, TOP

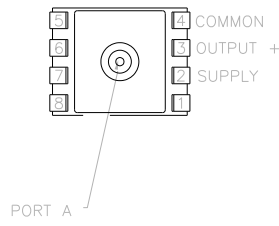

VERTICAL HOLE, DUAL

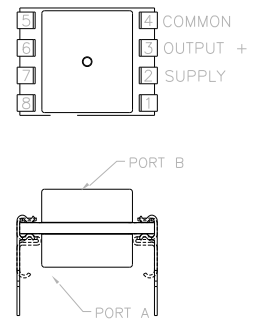

VERTICAL HOLE, DUAL,  
S/SL PIN STYLE

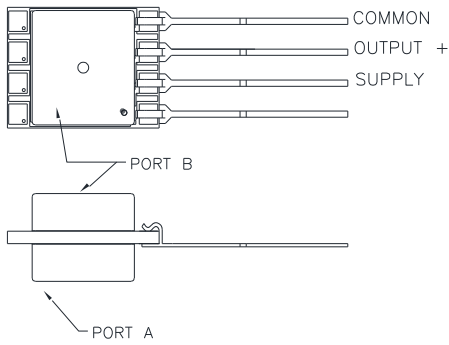

### PART NUMBERING FOR ORDERS

Series	Port Type	Package	Pressure Range	Pressure Units	Pressure Type (Range Availability) [Package Availability]	Calibrated Voltage	Output Type	Options
MCT-LL 4A	VHD=Vertical Hole, Dual	J= J lead SMT	025 050 100	cm=mmH20	G= Gage (All Ranges) [All Port Types]	3=3.3Vdc  5-5.0Vdc	Type1= 10 -90% of Supply Voltage  Type2= 5 -95% of Supply Voltage	-L Low Power  -DE Diagnostics Enabled (See Note 11)  -SP Switched Port (See Note 12)
	HBD=Horizontal Barb, Dual	T= DIL Thru Hole	250 500					
	VBT=Vertical Barb, Top	S=SIL	010 020					
	HBO=Horizontal Barb, Opposing	SL= SIL Long	050 100 200					
	HBT=Horizontal Barb, Top							

Part Number Example: **MCT-4LLA VBTJ010IG51**

**Vertical Barbed Top Port, J Leaded SMT Package, 0 to 10inH20 inH20 Range, 5.0Vdc Supply, Pmin=0 PSIG, Pmax=+ 10inH20**

### WARRANTY

Pressure sensors have a limited one-year warranty to the original purchaser. AVSensors will repair or replace, at its option, without charge those items it finds defective. This is the buyers sole remedy and is in lieu of all other warranties, expressed or implied, including those of merchantability and fitness for a particular purpose. In no event shall AVSensors be liable for consequential, special, or indirect damages. This warranty does not apply to units that have been modified, misused, neglected or installed where the application exceeds published ratings. Specifications may change without notice. The information supplied is believed to be accurate and reliable as of this printing, however, we assume no responsibility for its use.