

## CTO-7 SERIES

### CTO-7 Series

#### Transistor Outline (TO-8)

mV Output, Temperature Compensated  
Current Supply, Low Pressure



## DESCRIPTION

Advanced Sensor Ceramic TO Technology (CTO) 7 Series is a temperature compensated, mV output, PCB mounted pressure sensor packaged in a rugged Transistor Outline 8 pin (TO-8) package. The CTO-7 Series uses a dual bossed *low pressure* silicon MEMS pressure sensor mounted to a TO header with a separately soldered ceramic substrate that is uniquely laser trimmed and matched to each sensor. Available in gage and differential pressures and four different package configurations allow OEMs to optimize their board design. The CTO-7 series is powered with constant current and when configured as in the Application Note, the integrated gain set resistor will ensure sensor field interchangeability. Altogether, the CTO-7 series superior die performance, coupled with rugged ceramic substrate ensures long term stability with superior temperature performance over a wide operating range.

## APPLICATIONS

- Pneumatic controls
- Automotive diagnostics
- Medical equipment/instrumentation
- Dental equipment
- Environmental controls
- Barometric pressure measurement
- Altimeters
- Pneumatic controls

## FEATURES

- 1% Field Interchangeability
- inH<sub>2</sub>O ranges
- Wide selection of ports
- Differential or Gage pressures
- Temperature Compensated
- Linear High Output

## SPECIFICATIONS

	Symbol	Min	Typical	Max	Unit	Note
<b>Performance Characteristic (PSI Ranges)</b>						
Supply Voltage		0.5	1.5	2.0	mA	
Bridge Resistance, Input & Output		2500		6100	Ω	
Zero Pressure Offset		-2.0	±0.1	+2.0	mV	
Pressure Non Linearity		-0.1		+0.1	PSI	2
Hysteresis & Repeatability			0.05		%FSS	
Full Scale Span	FSS	65		150	mV	3
Temperature Hysteresis, Offset & Span		-	±0.1	+	%FSS	4
Thermal Error of Span		-1.0		+1.0	%FSS	
Thermal Error of Offset		-1.0		+1.0	%FSS	
Response Time			100		μS	
Insulation Resistance		50			M Ω	
Long Term Stability, Offset & Span			±0.2		%FSS	5
Weight				3	grams	
Compensated Temperature			0 to 50		°C	
Operating Temperatures			-40 to 125		°C	

SPECIFICATIONS	Symbol	Min	Typical	Max	Unit	Note
<b>Performance Characteristic (inH2O)</b>						
Supply Voltage		0.5	1.5	2.0	mA	
Bridge Resistance, Input & Output		2500		6100	Ω	
Zero Pressure Offset		-4.0	±0.1	+4.0	mV	
Pressure Non Linearity		-0.1		+0.1	PSI	2
Hysteresis & Repeatability			0.05		%FSS	
Full Scale Span (20inH2O)	FSS	45		70	mV	3
Full Scale Span (10inH2O)	FSS	30		80	mV	3
Temperature Hysteresis, Offset & Span		-	±0.5	+	%FSS	4
Thermal Error of Span		-2.5		+2.4	%FSS	
Thermal Error of Offset		-2.5		+2.5	%FSS	
Response Time			100		μS	
Insulation Resistance		50			M Ω	
Long Term Stability, Offset & Span			±0.4		%FSS	5
Weight				3	grams	
Compensated Temperature			0 to 50		°C	
Operating Temperatures			-40 to 125		°C	

SPECIFICATIONS	Symbol	Min	Typical	Max	Unit	Note
<b>Absolute Maximum Conditions</b>						5
Supply Voltage				3	mA	
Storage Temperature		-50		150	°C	
Overage Pressure						
Burst, Differential & Gage, Top Side				10x	Range	
Burst, Differential & Gage, Back Side				5x	Range	
Media Compatibility		CDA, Non Ionic, Non Corrosive Gases				
Wetted Materials		Top Port: RTV, Silicon, Glass, Nickel, Gold Bottom Port: RTV, Silicon, Glass, Gold				

**Reference Conditions:** Vsupply: 1.500mA, Ta=25°C. Pressure applied to top side of pressure port.

1. All specification at reference conditions unless otherwise noted. Output is ratio metric to supply voltage.
2. ½ Terminal Base Non Linearity (Measured at 0, 50% and 100% FS) measured from front side.
3. Full Scale Span output with sensor only. Field Interchangeability of 1% is guaranteed with use of Application Note.
4. Deviation between 50°C and 0°C expressed as percentage of reading at 25°C.
5. Deviation after 1 year period measured at reference conditions.
6. Exceeding Absolute Maximum Specification may damage the device. Extended exposure beyond the operating conditions may affect device reliability.

### EQUIVALENT CIRCUIT

### APPLICATION CIRCUIT

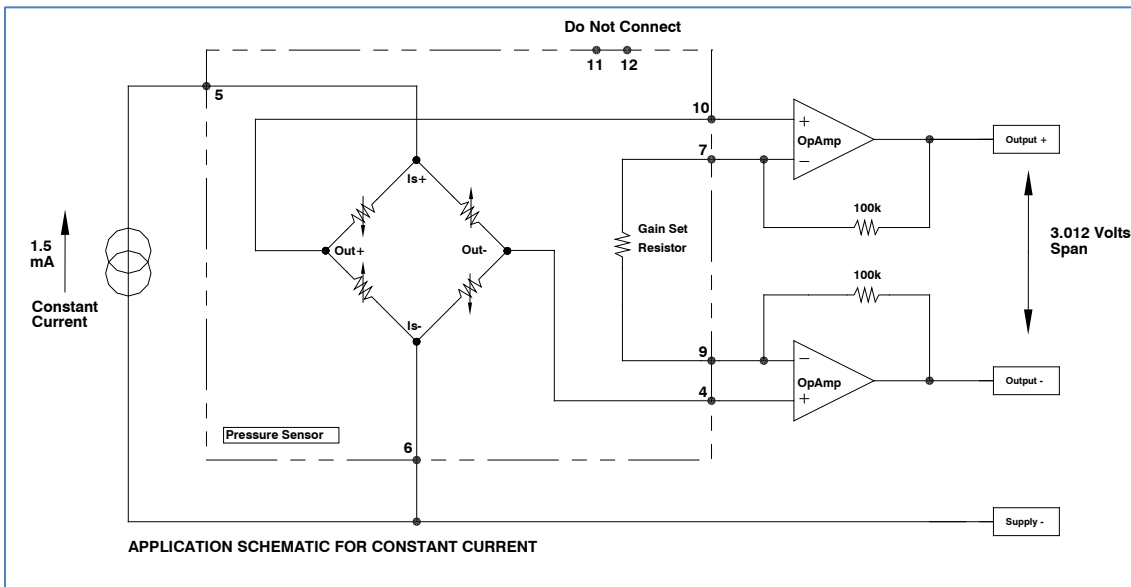
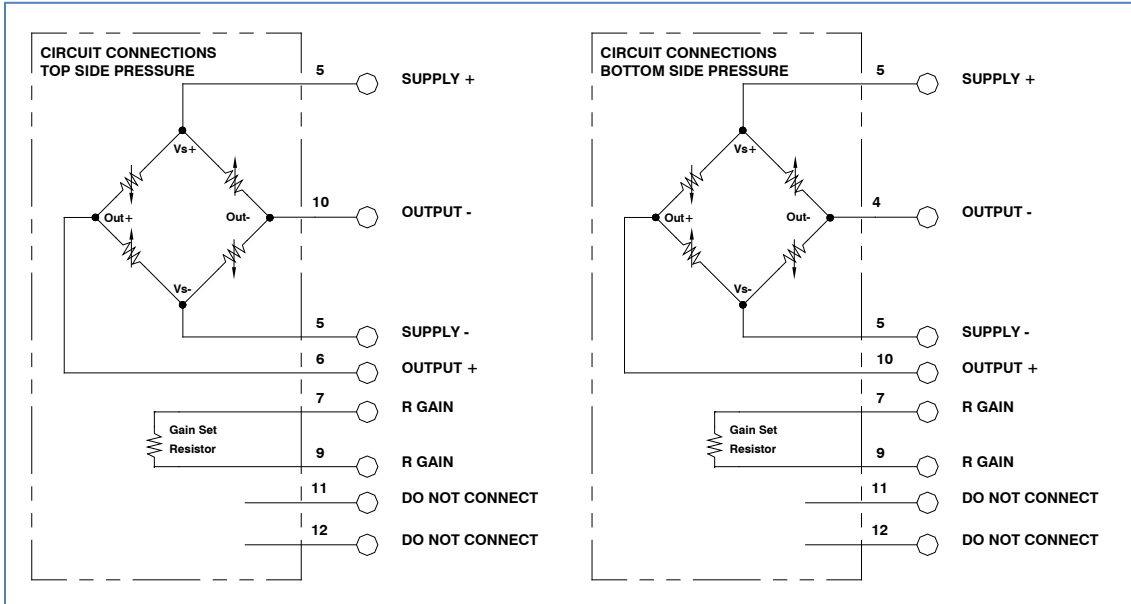

### MECHANICAL DIMENSIONS in [mm]

SINGLE TUBE

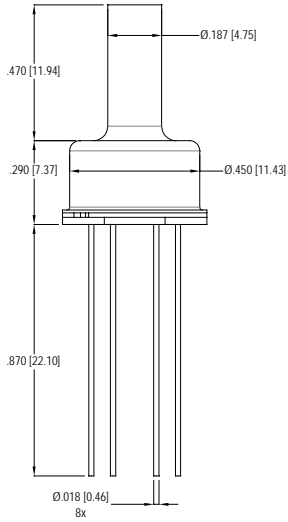

CAN

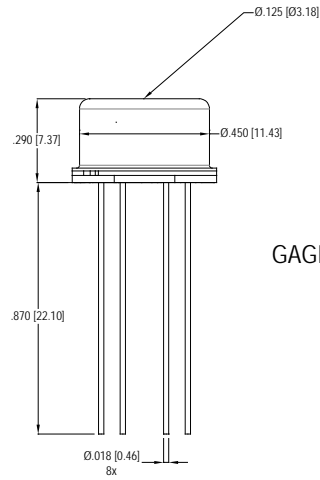

GAGE AND ABSOLUTE PRESSURES

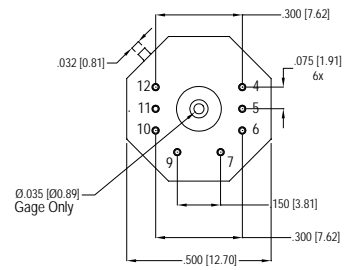

DUAL TUBE

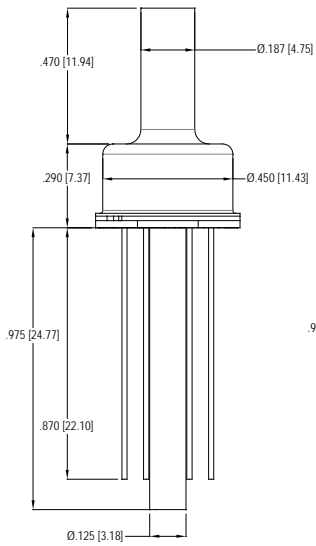

CAN & TUBE

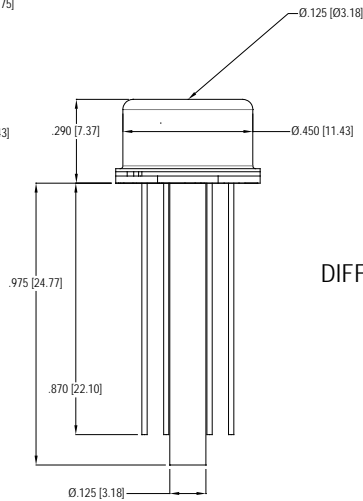

DIFFERENTIAL AND GAGE (BACKSIDE) PRESSURES

**PART NUMBERING FOR ORDERS**

Series	Port Style	Pressure Range	Pressure Units	Pressure Type (Range Availability) [Package Availability]	-Options
CTO-7	ST=Single Tube CN=Can DT=Dual Tube CT=Can & Tube	001	P=PSI	G=Gauge (All Ranges) [ST, CN, DT, CT]  D=Differential (All Ranges) [DT, CT]	-GC = Gel Coat
		010 020	H=inH2O		

**Part Number Example: CTO-7CT001PD-GC****0-1PSI Differential Can & Tube Port, Gel Coat****WARRANTY**

Pressure sensors have a limited one-year warranty to the original purchaser. AVSensors will repair or replace, at its option, without charge those items it finds defective. This is the buyer's sole remedy and is in lieu of all other warranties, expressed or implied, including those of merchantability and fitness for a particular purpose. In no event shall AVSensors be liable for consequential, special, or indirect damages. This warranty does not apply to units that have been modified, misused, neglected or installed where the application exceeds published ratings. Specifications may change without notice. The information supplied is believed to be accurate and reliable as of this printing, however, we assume no responsibility for its use.