

MIOF-85DO Series  
Media Isolated, Oil Filled,  
Process Fittings, 0.500 Diameter,  
Snubber Options  
Constant Voltage, Normalized Output



### DESCRIPTION

Advanced Sensor MIOF-85DO Series sensor is a media isolated pressure sensor designed for corrosive gases and liquids compatible with stainless 316L. The sensor design utilizes silicon oil to transfer pressure from the 316L diaphragm to the sensing element. The MIOF-85DO Series provides a 14bit digital pressure and 11 bit digital temperature output offered in SPI and I2C protocols. The rugged design is compatible with a wide range of harsh media including refrigerants, compressed air, and hydraulic fluids. The design's superior performance provides low thermal errors across a wide temperature range of -20 to 85°C. Available in gage and absolutes pressures with a flexible O-ring pressure port these sensors are ideal for OEM customer with ranges up to 500PSI.

### APPLICATIONS

- Process Controls
- Waste Water Measurements
- Medical Equipment/Instrumentation
- Pressure Transmitters
- Environmental Controls
- Hydraulic Controls

### FEATURES

- I2C & SPI Outputs
- Wide Availability Process Fittings/Customer Weldable
- Digital Temperature & Pressure Output
- 3.3 & 5.0Vdc Supply Voltages
- Absolute or Gage pressures
- Ribbon & Cable Electrical Connections
- Low Overall Errors, 1%TEB
- Low Power Option

### SPECIFICATIONS

	Symbol	Min	Typical	Max	Unit	Note
<b>Performance Specifications</b>						
Supply Voltage		2.7V	3.3	5.50	V	
Current Consumption				3	mA	
Standby Current			0.5		µA	-L
Pressure Resolution				14	bits	
Temperature Resolution				11	bits	
Output (Type 1) at Pmin			1638		cts	
Output (Type 1) at Pmax			14746		cts	
Output (Type 2) at Pmin			819		cts	
Output (Type 2) at Pmax			15564		cts	
Pressure Accuracy		-0.25		0.25	%FSS	2
Total Error Band	TEB	-1.00		1.00	%FSS	3
Temperature Accuracy			1.5		°C	
Long Term Stability			±0.4		%FSS	
Conversion Time			1.0		mS	4
Power On to Valid Data				<10	mS	5
Insulation Resistance (50Vdc), Pins to Case		50			M Ω	6
Compensated Temperature			-20 to 85		°C	
Compensated Temperature (5 PSI Range)			0 to 50		°C	
Operating Temperature			-40 to 125		°C	7

SPECIFICATIONS	Symbol	Min	Typical	Max	Unit	Note
<b>Absolute Maximum Conditions</b>						14
Supply Voltage		-5.0		6	V	
Storage Temperature		-40		125	°C	7
Package Integrity, Common Mode				300	psi	
Proof Pressure				2x		8
Burst Pressure				3x		9
Media Compatibility		Liquids & Gases Compatible with 316/316L Stainless Steel				
Wetted Materials		316/316L Stainless Steel				

**Reference Conditions:** Vsupply: 3.30Vdc or 5.00, Ta=25 °C

- All specification at reference conditions unless otherwise noted.
- Maximum deviation from a Best Fit Straight Line through Pmin and Pmax measured at 25 °C. Errors included Pressure Non Linearity, Pressure Hysteresis and Repeatability.
- Maximum deviation from the Ideal Transfer Function expressed as a percentage of the %FSS over the compensated temperature range. Includes calibration errors (Offset & Span), temperature errors (Offset & Span), pressure non-linearity, pressure and thermal hysteresis.
- The time for the output register to be updated with new data.
- The time for the output register to have valid data after a power on reset.
- Between case and sensing element.
- Maximum temperature range for product with standard cable and connector is -20°C to +105°C.
- Maximum pressure without degrading sensor's performance specifications.
- Maximum pressure the sensor package can withstand without rupture.
- Standard gage units are not recommended for vacuum applications. For vacuum applications below 1/2 atmosphere, consult factory.
- Device Marking: Each part shall be identified with Model Number, Pressure Range, Type, Lot Number, Serial Number and Date Code.
- Shipping/Packaging requirements: The stainless steel diaphragm is protected by a plastic CAP. Each unit will be packaged individually in a plastic vial with anti-static foam.
- Direct mechanical Contact with diaphragm is prohibited. Diaphragm surface must remain free of defects (scratches, punctures, dents, fingerprints, etc) for device to operate properly. Caution is advised when handling parts with exposed diaphragms. Use protective cap whenever devices are not in use.
- Exceeding Absolute Maximum Specification may damage the device. Extended exposure beyond the operating conditions may affect device reliability.

PRESSURE AND TEMPERATURE TRANSFER FUNCTIONS

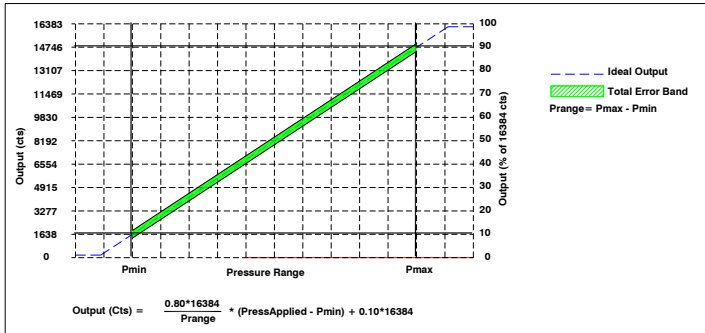

Type 1, 10-90%, Pressure Transfer Function

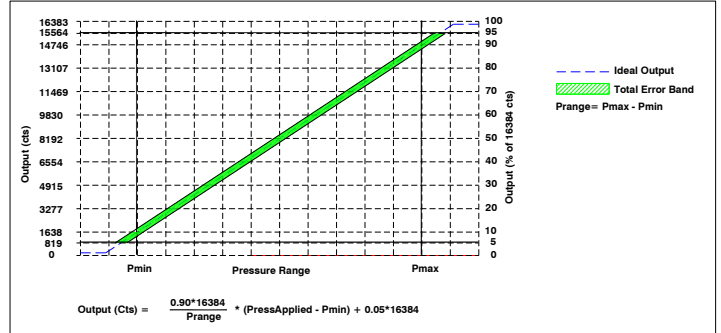

Type 2, 5-95%, Pressure Transfer Function

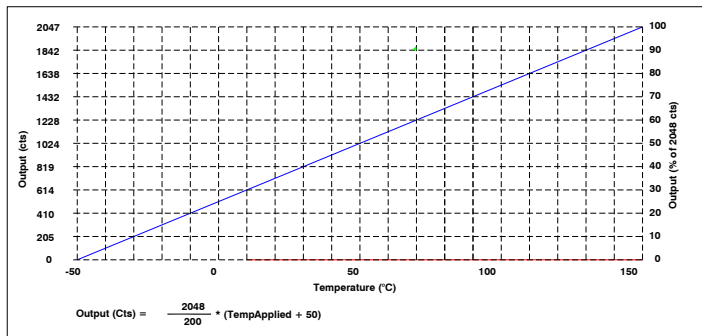

Temperature Transfer Function

### MECHANICAL DIMENSIONS in [mm]

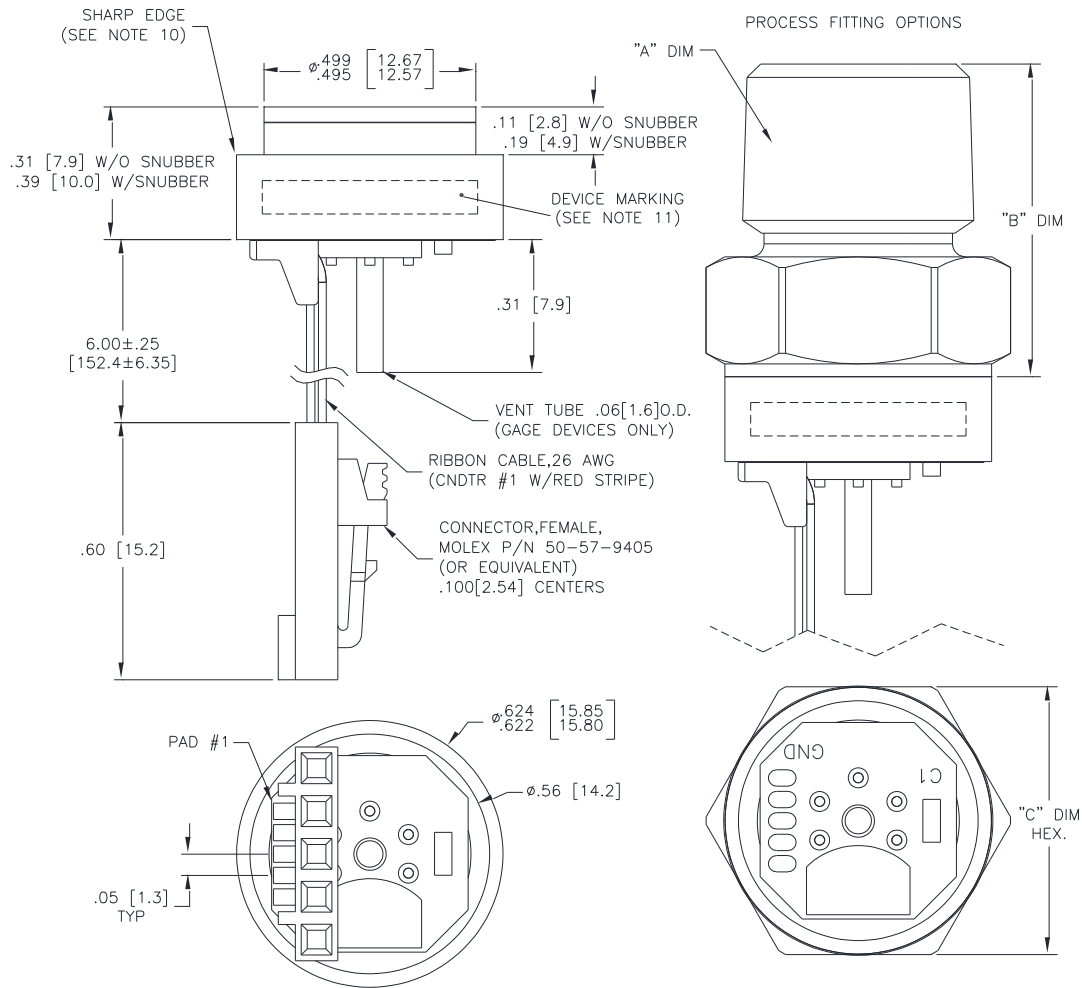

PAD/CNDTR	FUNCTION
1	GND
2	+EX
3	SDA/MISO
4	SCL/SCLK
5	INT/SS

FITTING DIMENSIONS			
FITTING TYPE	"A" DIM	"B" DIM	"C" DIM
1	1/4-18 NPT	.99[25.1]	7/8[22.2]
2	1/8-27 NPT	.96[24.4]	7/8[22.2]
3	7/16-20 UNF	.81[20.6]	7/8[22.2]
4	1/4-18 NPT	.93[23.6]	5/8[15.9]
5	1/4-19 BSP	.96[24.4]	3/4[19.0]
6	1/8-27 NPT	.80[20.3]	5/8[15.9]
7	1/4-19 BSP	.94[23.9]	7/8[22.2]

NOTE: FTG TYPE "4" ASSEMBLY SHOWN  
ALL DIMS FOR REFERENCE

### PART NUMBERING FOR ORDERS

Series	Port Type	Snubber	Pressure Range	Pressure Type (Range Availability) [Package Availability]	Calibrated Voltage	Output Type	Digital Protocol	Connection	Options
MIOF-85DO	P0=No Fitting Weldable  P1=1/4-18 NPT P2=1/8-27 NPT P3=7/6-20 UNF P4=1/4-18 NPT P5=1/4-19 BSP P6=1/8-27 NPT P7=1/4-19 BSP	0= No Snubber  1=With Snubber	001P 005P 015P 030P 050P 100P 300P 500P	A=Absolute (15,30,50,100,300,500) [ALL]  G=Gauge (All Ranges) [ALL]	3=3.3Vdc  5=5.0Vdc	1= 10 -90% of Supply Voltage  2= 5 -95% of Supply Voltage	I1=I2C, 0x28H I2=I2C, 0x38H I3=I2C, 0x48H [All Packages]  S1=SPI [All Packages]	P= Solder Pads  R= Ribbon Cable  C= Cable with Connector	-LT Low Power with Tube  -L Low Power No Tube  -T Tube

**Part Number Example: MIOF-85DO P11 005PG 31SR MIOF-85DO Series, 1/4NPT Process Port with Snubber, 0-5PSI Gage, Cable Termination, 3.3Vdc Supply, Pmin=0, Pmax=+ 5 PSI, SPI Protocol, Ribbon Cable Termination**

### WARRANTY

Pressure sensors have a limited one-year warranty to the original purchaser. AVSensors will repair or replace, at its option, without charge those items it finds defective. This is the buyers sole remedy and is in lieu of all other warranties, expressed or implied, including those of merchantability and fitness for a particular purpose. In no event shall AVSensors be liable for consequential, special, or indirect damages. This warranty does not apply to units that have been modified, misused, neglected or installed where the application exceeds published ratings. Specifications may change without notice. The information supplied is believed to be accurate and reliable as of this printing, however, we assume no responsibility for its use.