

MIOF-85CC Series
Media Isolated, Oil Filled,
Process Fittings, 0.500 Diameter,
Snubber Option
mV Output, Temperature Compensated
Constant Current Supply with Gain Set



DESCRIPTION

Advanced Sensor MIOF-85CC Series sensor is a media isolated pressure sensor designed for corrosive gases and liquids compatible with stainless 316L. The sensor design utilizes silicon oil to transfer pressure from the 316L diaphragm to the sensing element. The rugged design is compatible with a wide range of harsh media including refrigerants, compressed air, and hydraulic fluids. The series is powered using a constant current and when configured as in the Application Note, the integrated gain set resistor will ensure sensor field interchangeability to within 1%. The design's superior performance provides low thermal errors across a wide temperature range of 0 to 70°C.

Available in gage and absolute pressures with a flexible O-ring pressure port these sensors are ideal for OEM customer with ranges up to 500PSI.

APPLICATIONS

- Process Controls
- Waste Water Measurements
- Medical Equipment/Instrumentation
- Pressure Transmitters
- Environmental Controls
- Hydraulic Controls

FEATURES

- Field Interchangeability
- Constant Current
- Wide Availability Process Fittings
- Designed to Replace TE Connectivity/MEAS 85
- Absolute or Gage pressures
- Temperature Compensated
- 0.2% Pressure Non Linearity (Typical)
- Ribbon & Cable Electrical Connections

SPECIFICATIONS

	Symbol	Min	Typical	Max	Unit	Note
Performance Characteristic						
Full Scale Span	FSS	75		150	mV	1
Full Scale Span (1 & 5 PSI Range)	FSS	50		150	mV	1
Zero Pressure Offset		-1.0	±0.1	+1.0	mV	2
Zero Pressure Offset (1 & 5 PSI Range)		-2.0	±0.1	+2.0	mV	2
Pressure Non Linearity		-0.1		+0.1	%FSS	3
Pressure Non Linearity (5 PSI)		-0.2		+0.2	%FSS	3
Pressure Non Linearity (1 PSI)		-0.3		+0.3	%FSS	3
Pressure Hysteresis		-0.05	±0.02	+0.05	%FSS	
Pressure Hysteresis (1 & 5 PSI Range)		-0.1	±0.02	+0.1	%FSS	
Bridge Resistance, Input		2000		6500	Ω	
Bridge Resistance, Output		4000		7000		
Thermal Error of Span		-0.75		+0.75	%FSS	4
Thermal Error of Span (1 & 5 PSI Range)		-1.0		+1.0	%FSS	4
Thermal Error of Offset		-0.50		+0.50	%FSS	4
Thermal Error of Offset (1 & 5 PSI Range)		-2.50		+2.50	%FSS	4

Temperature Hysteresis, Span		-0.25		+0.25	%FSS	4
Temperature Hysteresis, Offset		-0.25		+0.25	%FSS	4
Long Term Stability, Offset			±0.10		%FSS	
Long Term Stability, Offset (1 & 5 PSI Range)			±0.25		%FSS	
Long Term Stability, Span			±0.10		%FSS	
Supply Current		0.5	1.5	2.0	mA	5
Output Load Resistance		5M			Ω	6
Insulation Resistance (50Vdc), Pins to Case		50			M Ω	7
Output Noise (10Hz to 1kHz)			1.0		uVp-p	
Rise Time			100		μS	
Compensated Temperature			0 to 70		°C	6
Compensated Temperature (1 PSI Range)			0 to 50		°C	6
Operating Temperatures			-40 to 125		°C	9
Operating Temperatures (1& 5 PSI Range)			-20 to 70		°C	9

SPECIFICATIONS	Symbol	Min	Typical	Max	Unit	Note
Absolute Maximum Conditions						14
Supply Current				3	mA	
Storage Temperature		-50		125	°C	9
Overage Pressure				4x	Range	8
Overage Pressure (1 PSI Range)				12x	Range	8
Proof Pressure				3x	Range	
Proof Pressure (1 PSI Range)				10x	Range	
Media Compatibility		Liquids & Gases Compatible with 316/316L Stainless Steel				
Wetted Materials		316L Stainless Steel				

Reference Conditions: Isupply: 1.500mA, Ta=25 °C.

- For amplified output circuits, 3.012V ±1% interchangeability with gain set resistor. See application schematic.
- Measured at vacuum for absolute (A), ambient for gage (G).
- Best fit straight line.
- Over the compensated temperature range with respect to 25°C.
- Guarantees output/input ratiometricity.
- Load resistance to reduce measurement errors due to output loading.
- Between case and sensing element.
- The maximum pressure that can be applied to a transducer without rupture of either the sensing element or transducer.
- Maximum temperature range for product with standard cable and connector is -20°C to +105°C.
- Standard gage units are not recommended for vacuum applications. For vacuum applications below 1/2 atmosphere, consult factory.
- Device Marking: Each part shall be identified with Model Number, Pressure Range, Type, Lot Number, Serial Number and Date Code.
- Shipping/Packaging requirements: The stainless steel diaphragm is protected by a plastic CAP. Each unit will be packaged individually in a plastic vial with anti-static foam.
- Direct mechanical Contact with diaphragm is prohibited. Diaphragm surface must remain free of defects (scratches, punctures, dents, fingerprints, etc) for device to operate properly. Caution is advised when handling parts with exposed diaphragms. Use protective cap whenever devices are not in use
- Exceeding Absolute Maximum Specification may damage the device. Extended exposure beyond the operating conditions may affect device reliability.

MECHANICAL DIMENSIONS in [mm]

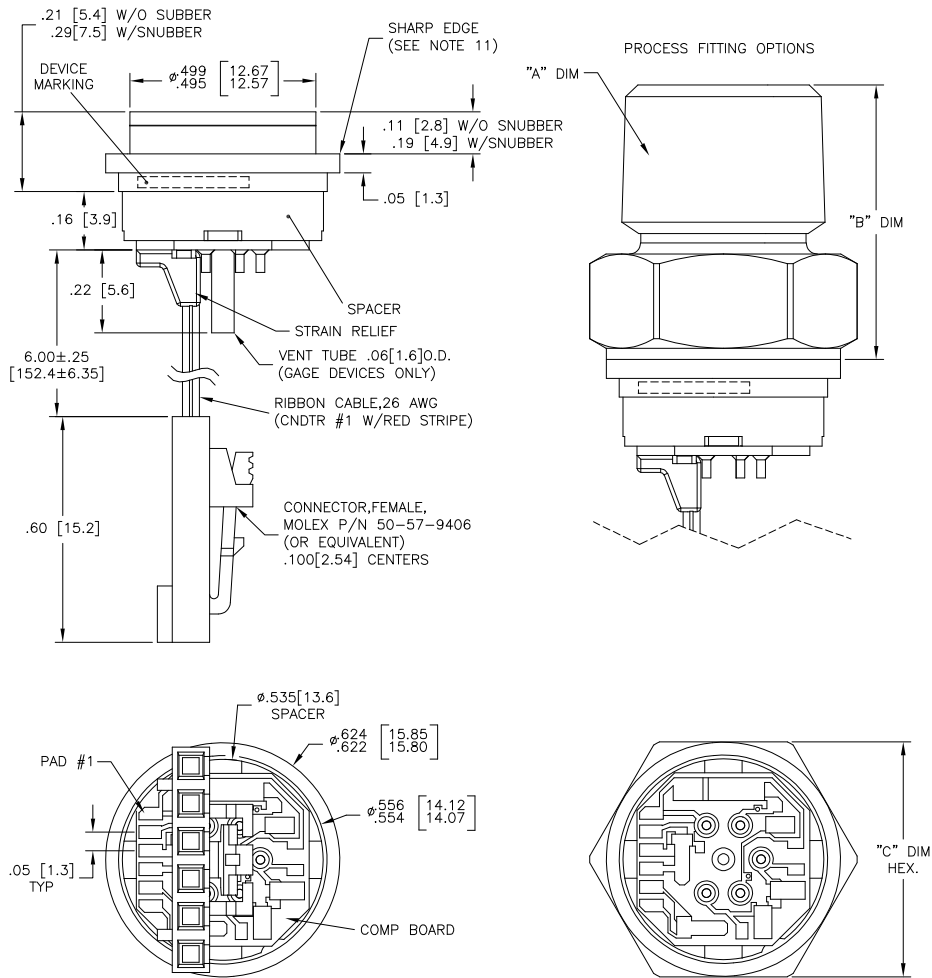

PAD/CNDR	FUNCTION
1	+OUT
2	-EX
3	+EX
4	-OUT
5	GAIN
6	

FITTING DIMENSIONS			
FITTING TYPE	"A" DIM	"B" DIM	"C" DIM
1	1/4-18 NPT	.99[25.1]	7/8[22.2]
2	1/8-27 NPT	.96[24.4]	7/8[22.2]
3	7/16-20 UNF	.81[20.6]	7/8[22.2]
4	1/4-18 NPT	.73[18.5]	5/8[15.9]
5	1/4-19 BSP	.76[19.3]	3/4[19.0]
6	1/8-27 NPT	.60[15.2]	5/8[15.9]
7	1/4-19 BSP	.94[23.9]	7/8[22.2]

NOTE: FTG TYPE "4" ASSEMBLY SHOWN
ALL DIMS FOR REFERENCE

EQUIVALENT CIRCUIT APPLICATION CIRCUIT

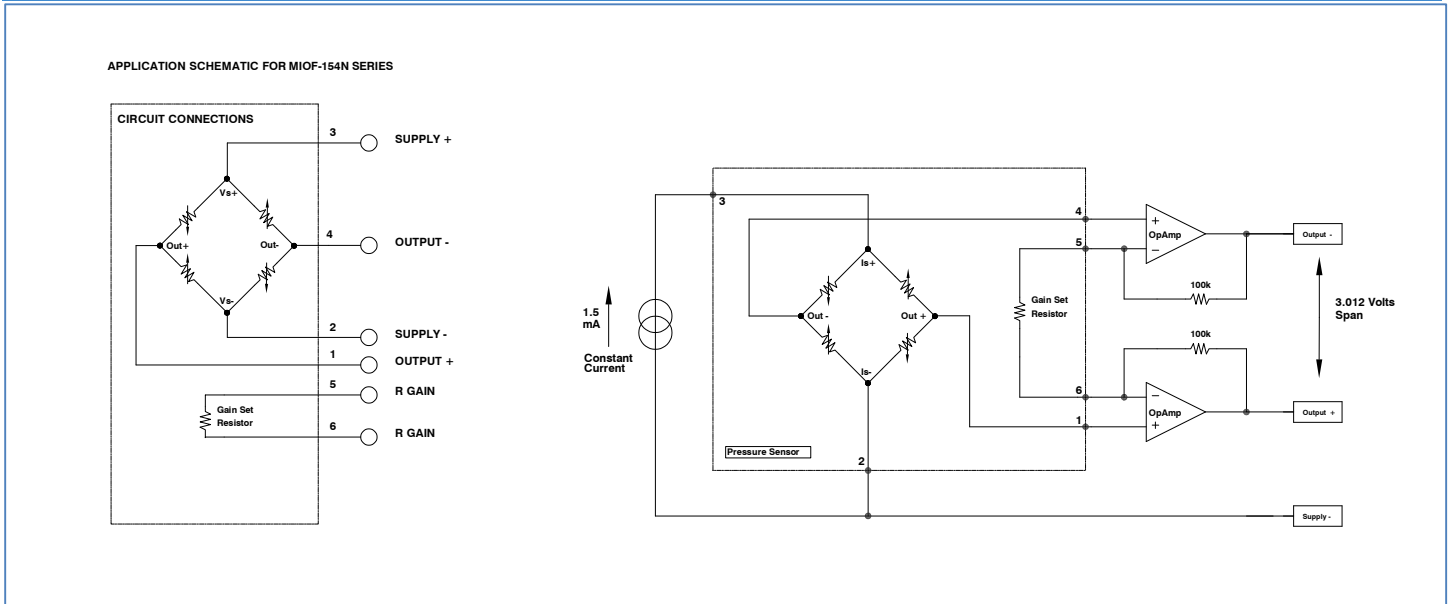

PART NUMBERING FOR ORDERS

Series	Port Style	Snubber	Pressure Range	Pressure Units	Pressure Type (Range Availability) [Package Availability]	Connection	Vent
MIOF-85CC	P0=O Ring P1=1/4-18 NPT P2=1/8-27 NPT P3=7/6-20 UNF P4=1/4-18 NPT P5=O 1/4-18 NPT P6=O 1/4-18 NPT P7=O 1/4-18 NPT	0= No Snubber 1=With Snubber	001 005 015 030 050 100 300 500	P=PSI	A=Absolute (15,30,50,100,300,500) [ALL] G=Gauge (All Ranges) [ALL]	P= Solder Pads R= Ribbon Cable C= Cable with Connector	VT= Vent Tube NT= No Tube

Part Number Example: MIOF-85CC P01 005PG CNT MIOF-85CC Series, O Ring Port, 0-5PSI Gage with Snubber, Cable Termination with No Vent Tube

WARRANTY

Pressure sensors have a limited one-year warranty to the original purchaser. AVSensors will repair or replace, at its option, without charge those items it finds defective. This is the buyers sole remedy and is in lieu of all other warranties, expressed or implied, including those of merchantability and fitness for a particular purpose. In no event shall AVSensors be liable for consequential, special, or indirect damages. This warranty does not apply to units that have been modified, misused, neglected or installed where the application exceeds published ratings. Specifications may change without notice. The information supplied is believed to be accurate and reliable as of this printing, however, we assume no responsibility for its use.